

“SCSI-IDE RAID Solution”



DATA SILO DS570 8-BAY SCSI-IDE RAID CHASSIS

PRODUCT DESCRIPTION

The Data Silo® DS570 is a cost-effective, high-performance RAID solution, integrating the StorCase Data Silo DS550 expansion chassis, Data Express® DE110 removable drive enclosures and a SCSI-IDE RAID controller. The DS570 provides a rugged and reliable RAID chassis for (8) Ultra ATA/100 IDE drives.

COLOR

White or black

CONSTRUCTION

Rugged steel

DEVICE SIZES SUPPORTED

3.5" Low-Profile

INTERFACES SUPPORTED

AT/IDE, Ultra ATA/66 and Ultra ATA/100

FEATURES

- Supports up to (8) high-capacity, high-speed low-profile Ultra ATA/100 IDE disk drives
- Supports dual Ultra160 SCSI host channels
- RAID levels 0, 1, 0+1, 3, and 5
- Dual hot swappable power supplies and blowers
- Automatic hot swap, hot spare and drive rebuild support
- O/S independent (no special software drivers required)
- Online Capacity Expansion (OCE) allows adding drives without downtime
- 128MB of PC-100 or PC-133 compatible SDRAM 144-pin SDIMM memory module
- Drive failure LED
- Supports up to 8 LUNs
- Drive activity on unit select indicators per bay
- Drive carrier key lock per bay
- Supports page/FAX notification event



DE110 carrier

RAID Controller
Included



DATA SILO DS570 8-BAY SCSI-IDE RAID CHASSIS

APPLICATIONS

- Server RAID (Web, E-mail, database)
- Data backup or archiving
- Departmental storage
- Video editing

UNIQUE PRODUCT BENEFITS

- Cost-effective IDE drive support in a high-performance SCSI enclosure
- Built-in RAID function for easy deployment
- Removable drive carriers interchangeable with StorCase Data Express® DE110 carriers
- All installation accessories provided
- 24/7 phone support. StorCase goes the extra mile to assist you with any product-related issues.

USER MARKETS

Finance
Education
Engineering
Government
Health Care
Insurance
Legal
Manufacturing
Real Estate
Entertainment
Construction
Retail
Telecommunications
OEM

TESTING/SUPPORT

- Tested in collaboration with the most prestigious peripheral manufacturers
- 30-day, money-back guarantee, *no questions asked*
- 7-year limited warranty
- 24/7 technical phone support
- Distributed worldwide

CONTACT INFORMATION

U.S. Sales/Marketing (800) 435-0642

U.K. Sales/Marketing (00800) 87 86 85 84

Technical Support (888) 435-5460

E-mail: info@storcase.com

www.storcase.com/dsilo/ds570.asp

StorCase[®]
TECHNOLOGY
A Kingston Technology Company

Providing rugged, upgradable storage products worldwide

Product Specifications

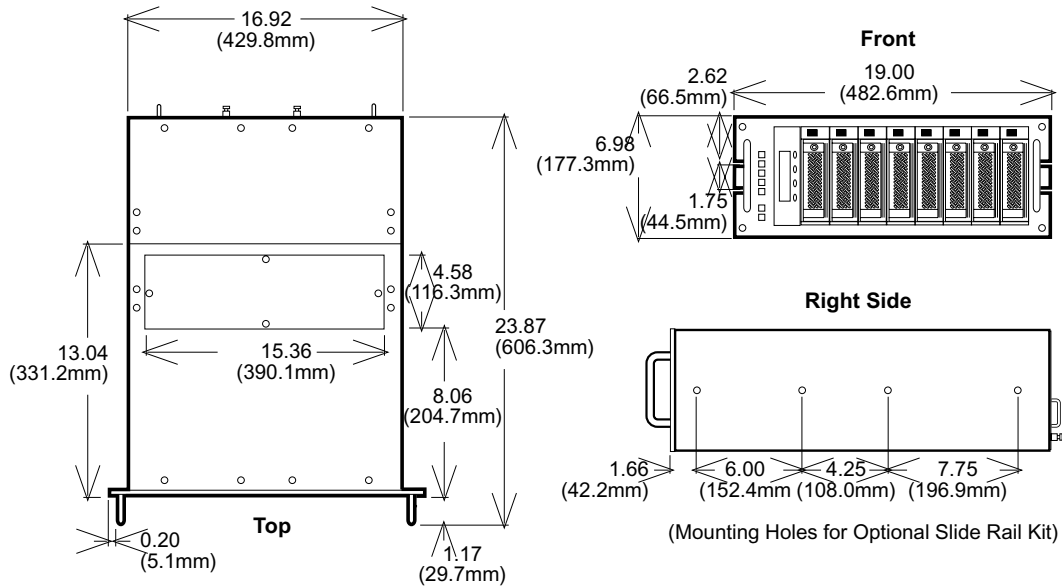

Environmental Specifications

| | Operating | Storage |
|----------------------------------|---------------------------------------|--|
| Ambient Temperature | 0°C to 35°C | -40°C to 70°C |
| Relative Humidity ⁽¹⁾ | 10% to 80% | 10% to 90% |
| Altitude | -1000 to 10,000 ft. -305m to 3048m | -1000 to 40,000 ft. -305m to 12195m |
| Shock ⁽²⁾ | 10g | 60g |

⁽¹⁾ Non-condensing with maximum gradient of 10% per hour

⁽²⁾ 11 msec pulse width 1/2 sine wave

Physical Specifications

| | Rack Mount |
|--------|---------------------------------|
| Height | 6.98" (177.3mm) |
| Width | 19.00" (482.6mm) |
| Depth | 23.87" (606.3mm) ⁽¹⁾ |
| Weight | 70lbs (31.8kg) ⁽²⁾ |

⁽¹⁾ Includes front chassis handles

⁽²⁾ Total weight including DE110s (without drives installed)

Electrical Specifications

| (2) Auto Ranging 400 Watt (500W _{Peak}) Power Supplies ⁽¹⁾ | |
|---|-------------------------------|
| AC Input | 100-240VAC, 60/50Hz at 8 AMPS |
| DC Output Continuous | 5V at 21.5A, 12V at 24.5A |
| DC Output Peak | 12V at 38A (15 sec. max) |

⁽¹⁾ Dual power supplies operate in shared mode.

Chassis Reliability/Maintainability

| Chassis | |
|--------------------------|-----------------------------|
| MTBF ⁽¹⁾ | 250,000 Hours |
| Preventative Maintenance | Power Supply/Blower Modules |

(1) MTBR = Mean Time Between Failure

Air Flow

| | |
|---------------------|---------|
| Total for 2 Blowers | 79 CFMs |
|---------------------|---------|

